

Hydro - Chuck MX 240/400

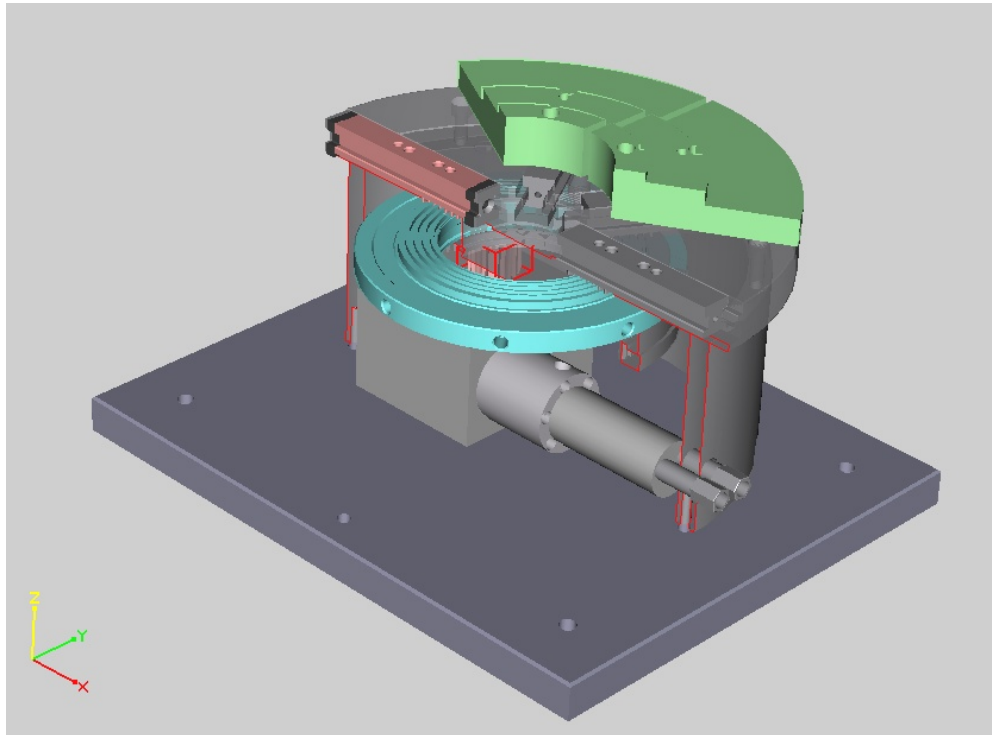

Application field:

- For safe loading of thin-walled rings
- External or internal loading

Technical data:

- Standard: 2 models, $\varnothing 240$ and $\varnothing 400$
- Drive: Hydraulic max. pressure 100 bar
- Loading force: 500-4500 daN

Advantages:

- Positive loading
- No deformation of work pieces while and after machining
- Safe and fast loading
- Maintenance-free

Options:

- Hydraulic set
- Control